

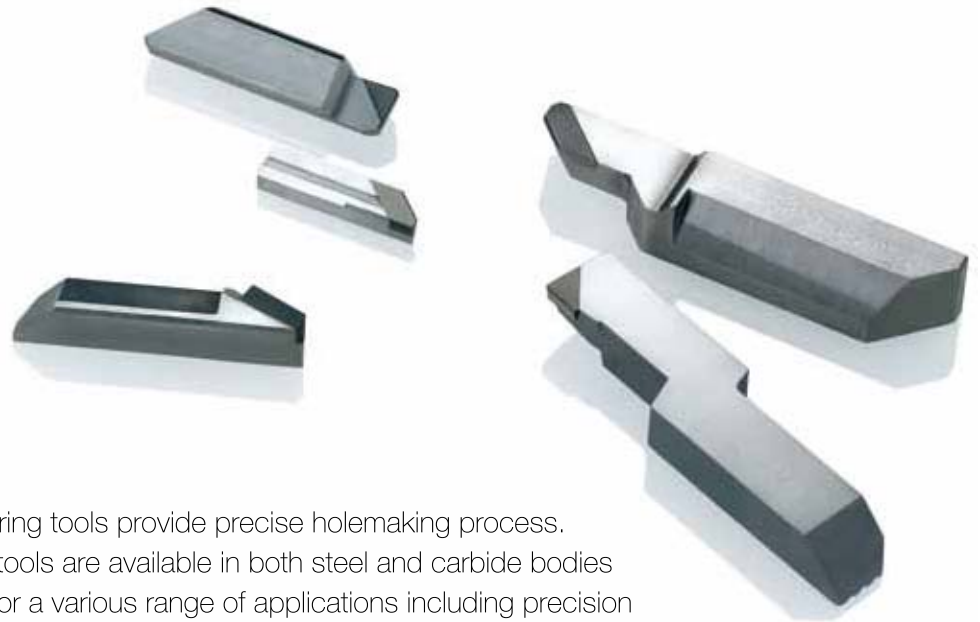

Boring



The EHW A boring tools provide precise holemaking process. These trustful tools are available in both steel and carbide bodies and are ideal for a various range of applications including precision micro boring.



BS type | PCD/PCBN

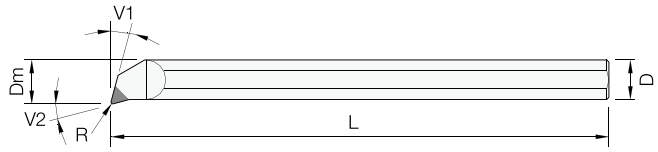

Item No.	Dimensions (mm)						PCD		PCBN	
	R	V1	V2	L	D	Dm	EP20	EP55	EB190	EB51
BSR 25 60 005	0.05	15	15	60	2.5	3				
25 60 01	0.1	15	15	60	2.5	3				
30 60 005	0.05	15	15	60	3	3.5				
30 60 01	0.1	15	15	60	3	3.5				
40 60 01	0.1	15	15	60	4	4.5				
40 60 02	0.2	15	15	60	4	4.5				
50 60 01	0.1	15	15	60	5	5.5				
50 60 02	0.2	15	15	60	5	5.5				
60 80 01	0.1	15	15	80	6	7				
60 80 02	0.2	15	15	80	6	7				

BS type | PCD/PCBN

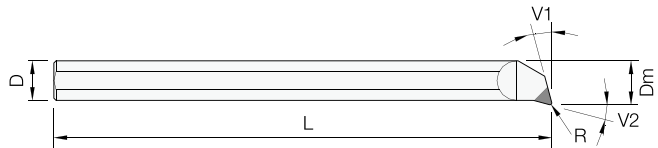

Item No.	Dimensions (mm)						PCD		PCBN	
	R	V1	V2	L	D	Dm	EP20	EP55	EB190	EB51
BSL 25 60 005	0.05	15	15	60	2.5	3				
25 60 01	0.1	15	15	60	2.5	3				
30 60 005	0.05	15	15	60	3	3.5				
30 60 01	0.1	15	15	60	3	3.5				
40 60 01	0.1	15	15	60	4	4.5				
40 60 02	0.2	15	15	60	4	4.5				
50 60 01	0.1	15	15	60	5	5.5				
50 60 02	0.2	15	15	60	5	5.5				
60 80 01	0.1	15	15	80	6	7				
60 80 02	0.2	15	15	80	6	7				

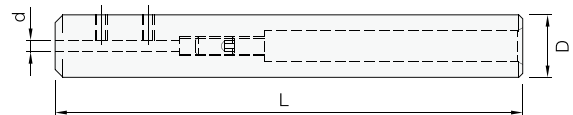

Item No.	Dimensions (mm)				
	d	L	H	D	
SLV 16 025	2.5	100	14	16	
16 03	3	100	14	16	
16 04	4	100	14	16	
16 05	5	100	14	16	
16 06	6	100	14	16	

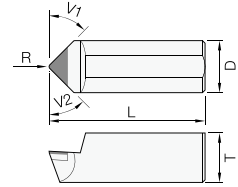

BR type | PCD/PCBN

Item No.	Dimensions (mm)					PCD		PCBN	
	R	V1	V2	L	D	EP20	EP55	EB190	EB51
BRC 40 15 02	0.2	45	45	15	4				
40 15 04	0.4	45	45	15	4				
50 15 02	0.2	45	45	15	5				
50 15 04	0.4	45	45	15	5				
60 20 02	0.2	45	45	20	6				
60 20 04	0.4	45	45	20	6				
80 30 04	0.4	45	45	30	8				
80 30 08	0.8	45	45	30	8				

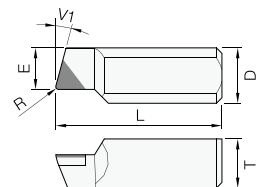

BR type | PCD/PCBN

Item No.	Dimensions (mm)						PCD		PCBN	
	R	V1	E	L	D	T	EP20	EP55	EB190	EB51
BRR 40 15 02	0.2	15	15	15	4	3.5				
40 15 04	0.4	15	15	15	4	3.5				
50 15 02	0.2	15	15	15	5	4.5				
50 15 04	0.4	15	15	15	5	4.5				
60 20 02	0.2	20	20	20	6	5.5				
60 20 04	0.4	20	20	20	6	5.5				
80 30 04	0.4	30	30	30	8	7				
80 30 08	0.8	30	30	30	8	7				

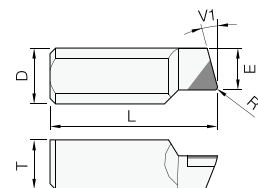

BR type | PCD/PCBN

Item No.	Dimensions (mm)						PCD		PCBN	
	R	V1	E	L	D	T	EP20	EP55	EB190	EB51
BRL 40 15 02	0.2	15	15	15	4	3.5				
40 15 04	0.4	15	15	15	4	3.5				
50 15 02	0.2	15	15	15	5	4.5				
50 15 04	0.4	15	15	15	5	4.5				
60 20 02	0.2	20	20	20	6	5.5				
60 20 04	0.4	20	20	20	6	5.5				
80 30 04	0.4	30	30	30	8	7				
80 30 08	0.8	30	30	30	8	7				

MEMO

EHWA

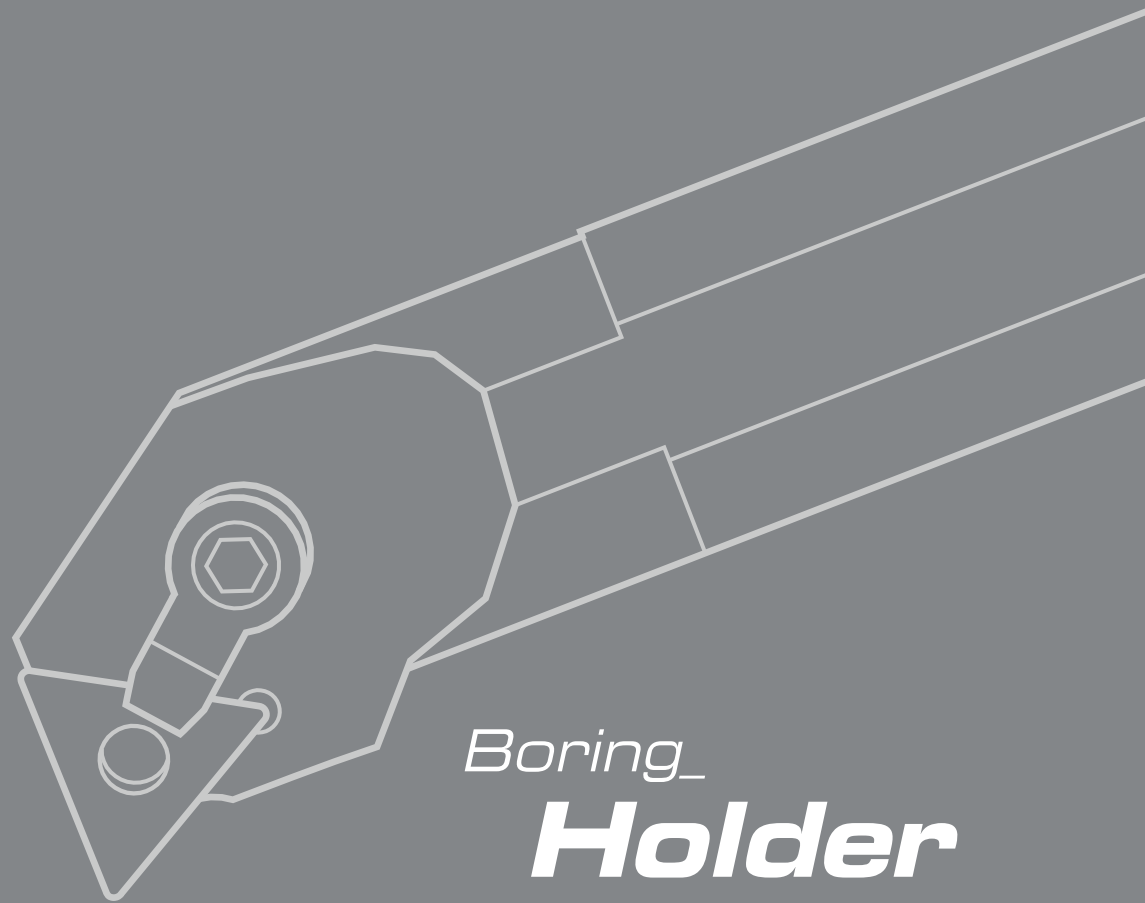

Boring_
Holder

How to combine the holder

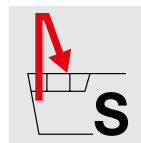
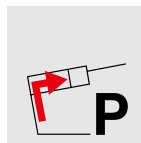
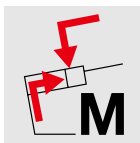
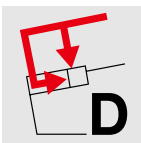

- D** Double clamping
- M** Multi locking
- P** Lever locking
- S** Screw clamping

E

25

R

M

Shank material

Insert diameter

Tool length

Clamp type

A	STEEL SHANK+OIL HOLE
E	TC SHANK+OIL HOLE
C	TC SHANK
S	STEEL SHANK
X	SPECIAL

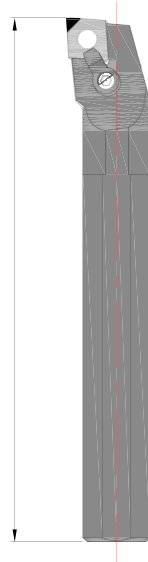
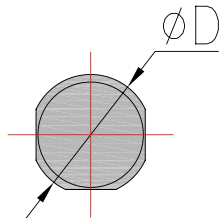

Symbol (L)	Length (mm)
H	100
J	110
K	125
M	150
N	160
Q	180
R	200
S	250
T	300
U	350
V	400
W	450
Y	500

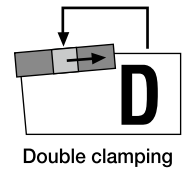

Double clamping

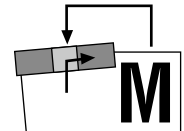

Multi locking

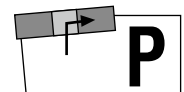

Lever locking

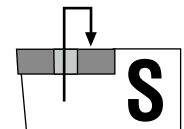

Screw clamping

S K D R - 12

1

Insert shape **Tool style** **Clearance angle** **Cutting direction**

Symbol	Shape
C	
D	
K	
S	
T	
V	
W	

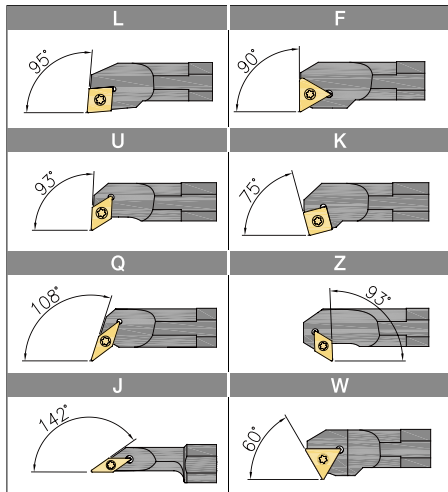

Symbol	Angle
N	0°
B	5°
C	7°
P	11°

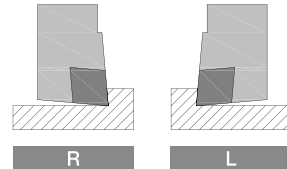

1 Cutting edge length

C	D	E	R	S	T	V	W	K	I.C size (mm)
03	04			03	06				3.97
05	06			05	09	09	03		5.56
06	07			06	11	11	04		6.35
08	09			07	13	13	05		7.94
			08						8
09	11		09	09	16	16	06	16	9.525
			10						10
			12						12
12	15	13	12.7	12	22	22	08		12.7
16	19		15	15	27	27	10		15.875
			16						16
19	23		19	19	33	33	13		19.05
			20						20
			25						25
25	31		25	25	44				25.4
			32						32

Tool Holder Clamping Type

Double clamping

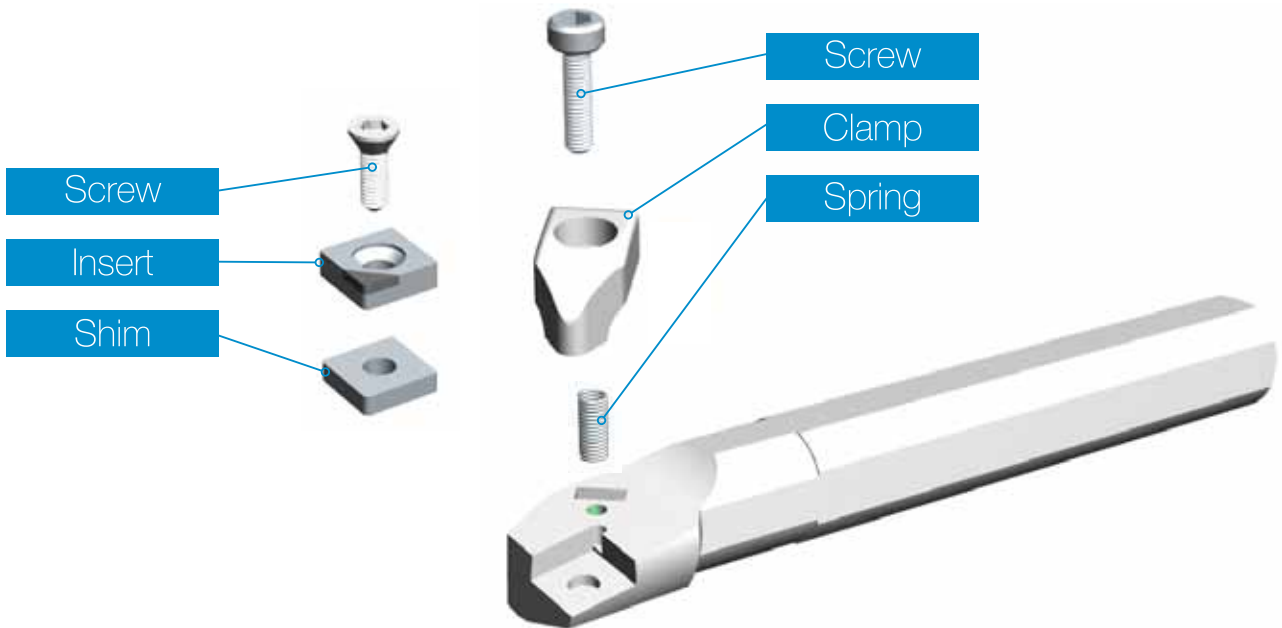

Multi locking

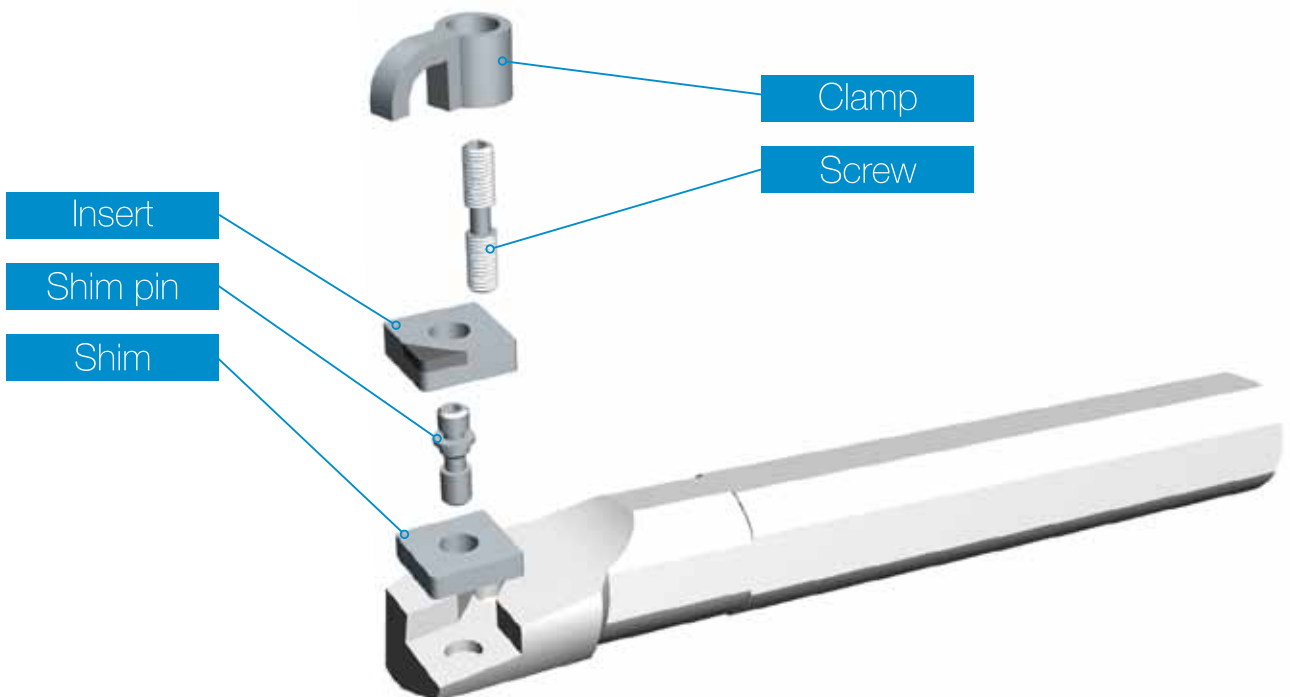

Lever locking

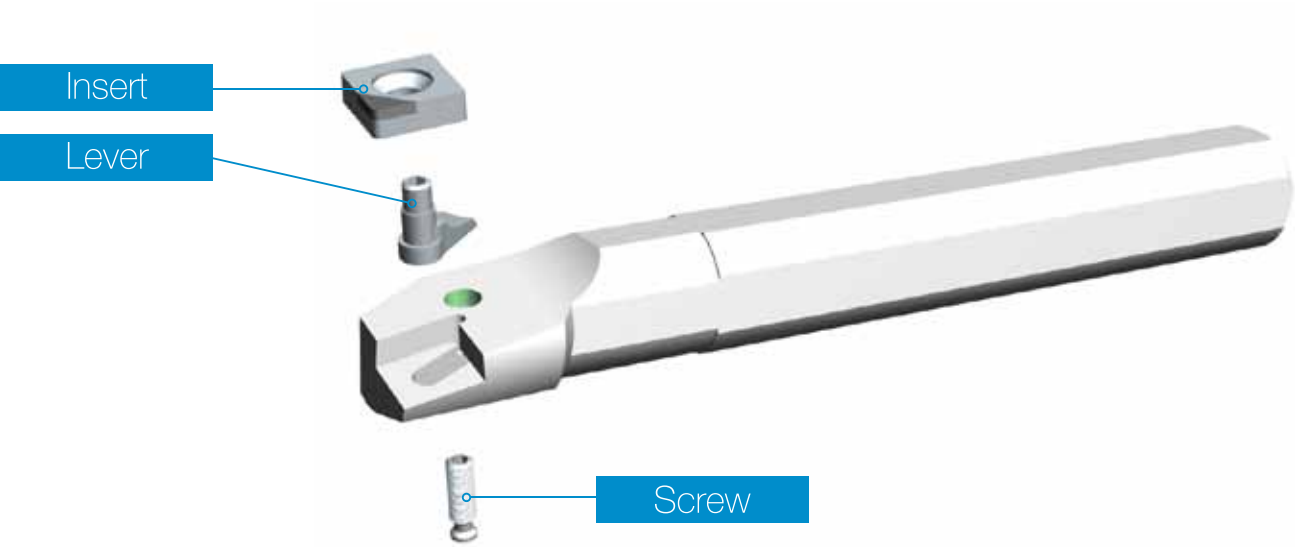

Screw clamping

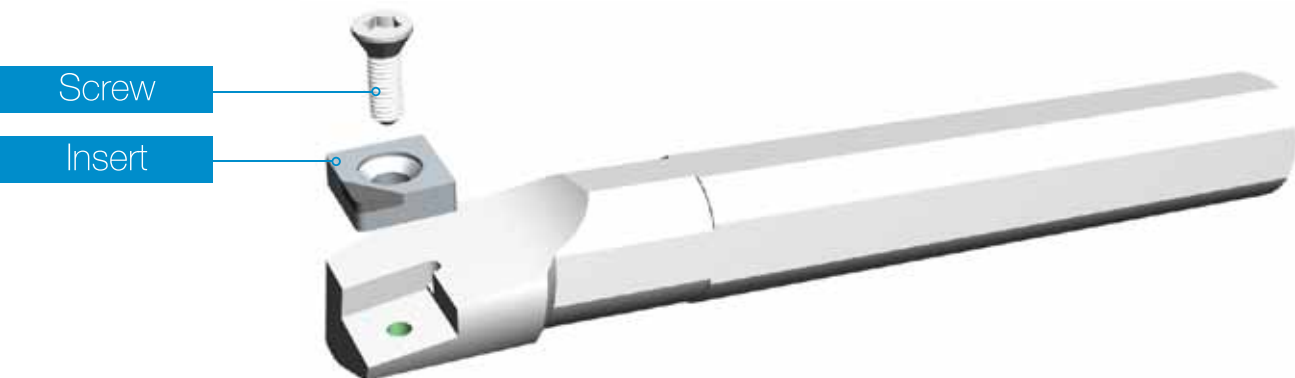

Application Of Holder

Lever lock system

Cutting shape						
Designation	PCLNR/L	PDSNR/L	PDUNR/L	PSKNR/L	PTFNR/L	PWLNRL
Approach angle	95°	62.5°	93°	75°	90°	95°
Page	108	108	109	109	110	110
Copying		●	●			
Facing	●					●
Back truning		●	●			●
Turning	●	●	●	●	●	●

Multi lock system

Cutting shape						
Designation	MTFNR/L	MVUNR/L	MWLNR/L	MCLNR/L	MDUNR/L	MSKNR/L
Approach angle	90°	93°	95°	95°	93°	75°
Page	111	111	111	119	119	119
Copying		●			●	
Facing			●	●		
Back truning		●			●	
Turning	●	●	●	●	●	●

Screw on system

Cutting shape								
Designation	SCLCR/L	SCLPR/L	SDQCR/L	SDUCR/L	SDZCR/L	SSKCR/L	SSKPR/L	STFCR/L
Approach angle	95°	95°	107.5°	93°	3°	75°	75°	90°
Page	112	112	113	113	114	114	115	115
Copying			•	•				
Facing	•	•						
Back truning			•	•	•			
Turning	•	•	•	•	•	•	•	•

Cutting shape								
Designation	STFPR/L	STWPR/L	SVJCR/L	SVQBR/L	SVQCR/L	SVUBR/L	SVUCR/L	SWLCR/L
Approach angle	90°	60°	142°	108°	108°	93°	93°	95°
Page	116	114	116	117	117	117	118	118
Copying			•	•	•	•	•	•
Facing								
Back truning				•	•	•	•	•
Turning	•	•	•	•	•	•	•	•

PCLN^{R/L} Lever Locking

+ CN □ □

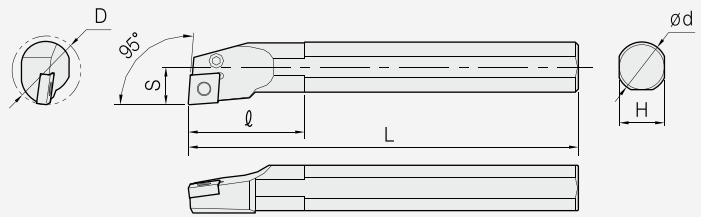

Insert	Item No.	Dimensions (mm)						Lever	Screw	Shim	Shim Pin	Shim pin punch	Wrench
		øD	ød	H	L	S	l						
CN □ □ 0903 □ □	EH-S16R-PCLN R/L-09	20	16	15	200	11	28	LV3C	LVSCR0509B	-	-	-	W20L
	EH-S20S-PCLN R/L-09	25	20	18	250	19	32						
	EH-S25R-PCLN R/L-09	32	25	23	200	17	36						
CN □ □ 1204 □ □	EH-S25R-PCLN R/L-12	32	25	23	200	17	40	LV4A	LVSCR0613A	-	-	-	W25L
CN □ □ 1204 □ □	EH-S32S-PCLN R/L-12	40	32	30	250	22	50	LV4	LVSCR0821	LVSC42B	LVSP4	LVSP4	W30L
	EH-S40T-PCLN R/L-12	50	40	37	300	27	55						
	EH-S50U-PCLN R/L-12	63	50	47	350	35	55						

PDSN^{R/L} Lever Locking

+ DN □ □

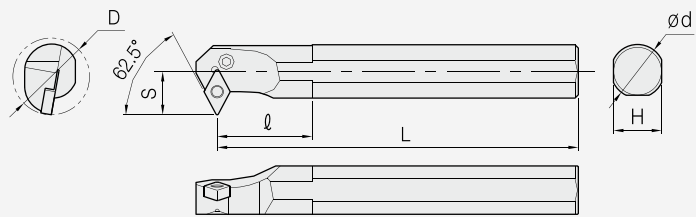

Insert	Item No.	Dimensions (mm)						Lever	Screw	Shim	Shim Pin	Shim pin punch	Wrench
		øD	ød	H	L	S	l						
DN □ □ 1506 □ □	EH-S32S-PDSN R/L-15	40	32	30	250	22	45	LV4B	LVSCR0821	LVSD42	LVSP4	LVSP4	W30L
	EH-S40T-PDSN R/L-15	50	40	37	300	27	43						
DN □ □ 1504 □ □	EH-S32S-PDSN R/L-15-3	40	32	30	450	22	45	LV4	LVSCR0821	LVSD42	LVSP4	LVSP4	W30L
	EH-S40T-PDSN R/L-15-3	50	40	37	300	27	43						
DN □ □ 1506 □ □	EH-A32S-PDSN R/L-15	40	32	31	250	22	45	LV4B	LVSCR0821	LVSD42	LVSP4	LVSP4	W30L
DN □ □ 1504 □ □	EH-A32S-PDSN R/L-15-3	40	32	31	250	22	45	LV4	LVSCR0821	LVSD42	LVSP4	LVSP4	W30L

PDUN^{R/L}

Lever Locking

+ DN □□ □□

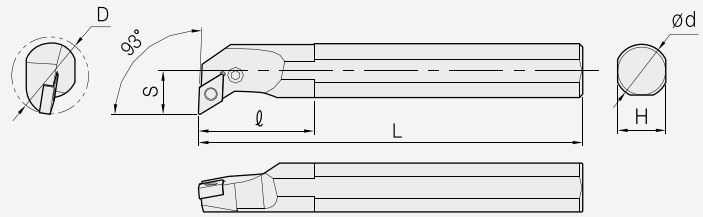

Insert	Item No.	Dimensions (mm)						Lever	Screw	Shim	Shim Pin	Shim pin punch	Wrench
		øD	ød	H	L	S	l						
DN □□ 1104 □□	EH-S20S-PDUN R/L-11	25	20	18	250	13	30	LV3D	LVSCR0512B	-	-	-	W20L
	EH-S25R-PDUN R/L-11	32	25	23	200	17	35	LV3	LVSCR0617	LVSD317	LVSP3	LVSP3	W25L
	EH-S32S-PDUN R/L-11	40	32	30	250	22	40						
DN □□ 1506 □□	EH-S32S-PDUN R/L-15	40	32	30	250	22	50	LV4B	LVSCR0821	LVSD42	LVSP4	LVSP4	W30L
	EH-S40T-PDUN R/L-15	50	40	37	300	27	50						
	EH-S50U-PDUN R/L-15	63	50	47	350	35	63						
DN □□ 1504 □□	EH-S32S-PDUN R/L-15-3	40	32	30	250	22	50	LV4	LVSCR0821	LVSD42	LVSP4	LVSP4	W30L
	EH-S40T-PDUN R/L-15-3	50	40	37	300	27	50						
DN □□ 1506 □□	EH-A32S-PDUN R/L-15	40	32	31	250	22	50	LV4B	LVSCR0821	LVSD42	LVSP4	LVSP4	W30L
DN □□ 1504 □□	EH-A32S-PDUN R/L-15-3	40	32	31	250	22	50	LV4	LVSCR0821	LVSD42	LVSP4	LVSP4	W30L

PSKN^{R/L}

Lever Locking

+ SN □□ □□

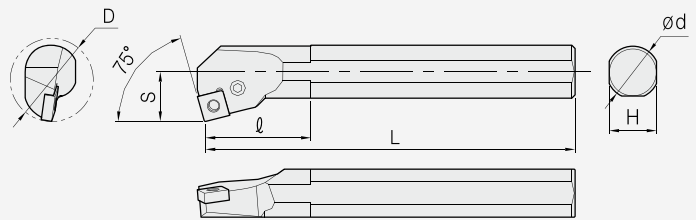

Insert	Item No.	Dimensions (mm)						Lever	Screw	Shim	Shim Pin	Shim pin punch	Wrench
		øD	ød	H	L	S	l						
SN □□ 1204 □□	EH-S25R-PSKN R/L-12	32	25	23	200	17	42	LV4A	LVSCR0613A	-	-	-	W25L
	EH-S32S-PSKN R/L-12	40	32	30	250	22	45	LV4	LVSCR0821	LVSS42B	LVSP4	LVSP4	W30L
	EH-S40T-PSKN R/L-12	50	40	37	300	27	50						
SN □□ 1204 □□	EH-A25R-PSKN R/L-12	32	25	23	200	17	42	LV4A	LVSCR0613A	-	LVSP4	-	W25L
SN □□ 1204 □□	EH-A32S-PSKN R/L-12	40	32	30	250	22	50	LV4	LVSCR0821	LVSS42B	LVSP4	LVSP4	W30L

PTFN^{R/L} Lever Locking

+ TN □ □

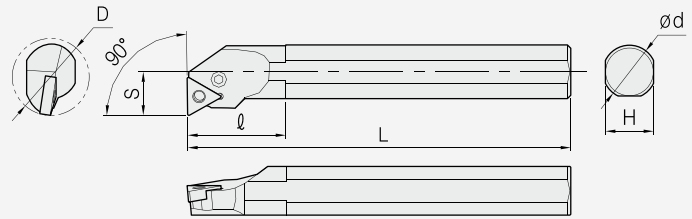

Insert	Item No.	Dimensions (mm)						Lever	Screw	Shim	Shim Pin	Shim pin punch	Wrench
		øD	ød	H	L	S	l						
TN □ □ 103 □ □	EH-S16R-PTFN R/L-11	20	16	15	200	11	28	LV2	LVSCR0509B	-	-	-	W25L
	EH-S20S-PTFN R/L-11	25	20	18	250	13	33						
	EH-S25R-PTFN R/L-11	32	25	23	200	17	36						
TN □ □ 1604 □ □	EH-S25R-PTFN R/L-16	32	25	23	200	17	42	LV3B	LVSCR0512B	-	-	-	W20L
	EH-S32S-PTFN R/L-16	44	32	30	250	22	50						
	EH-S40T-PTFN R/L-16	54	40	37	300	27	55						
	EH-A25R-PTFN R/L-16	32	25	24	200	17	40						
	EH-A32S-PTFN R/L-16	40	32	31	250	22	50						

PWLN^{R/L} Lever Locking

+ WN □ □

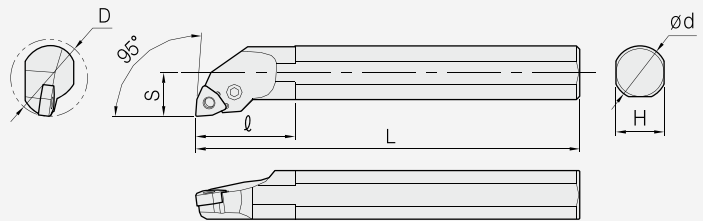

Insert	Item No.	Dimensions (mm)						Lever	Screw	Shim	Shim Pin	Shim pin punch	Wrench
		øD	ød	H	L	S	l						
WN □ □ 0604 □ □	EH-S20S-PWLN R/L-06	25	20	18	250	13	40	LV3B	LVSCR0512B	-	-	-	W20L
	EH-S25R-PWLN R/L-06	32	25	23	200	17	40						
	EH-S32S-PWLN R/L-06	44	32	30	250	22	45						
WN □ □ 0804 □ □	EH-S25R-PWLN R/L-08	32	25	23	200	17	45	LV4A	LVSCR0613A	-	-	-	W25L
	EH-S32S-PWLN R/L-08	44	32	30	250	22	50						

MTFN^{R/L}

Multi Locking

+ TN □□

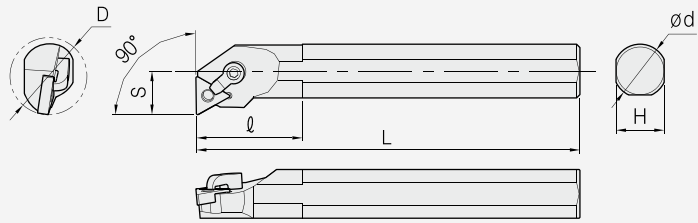

Insert	Item No.	Dimensions (mm)						Clamp	Clamp Screw	Shim	Shim Pin	Wrench
		ØD	Ød	H	L	S	l					
TN □□1604 □□	EH-S25R-MTFN R/L-16	32	25	23	200	17	36	MCL7N1	MCSCR10-32-19	-	MSP3D3	W23.8L
	EH-S32S-MTFN R/L-16	40	32	30	250	22	50			MST32D	MSP3D	W19.8L
	EH-S40T-MTFN R/L-16	50	40	37	300	27	60			-	MSP3D3	W23.8L
	EH-A25R-MTFN R/L-16	32	25	23	200	17	40			MST32D	MSP3D	W19.8L
	EH-A32S-MTFN R/L-16	40	32	30	250	22	50			-	MSP3D3	W23.8L

MVUN^{R/L}

Multi Locking

+ VN □□

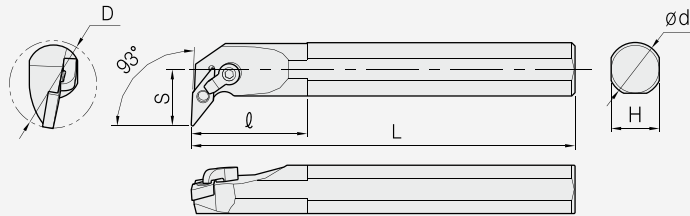

Insert	Item No.	Dimensions (mm)						Clamp	Clamp Screw	Shim	Shim Pin	Wrench
		ØD	Ød	H	L	S	l					
VN □□1604 □□	EH-S32S-MVUN R/L-16	40	32	30	250	22	50	MCL8N2	MCSCR5/16-28	MSV32	MSP3D	W39.7L W19.8L
	EH-S40T-MVUN R/L-16	50	40	37	300	27	60					
	EH-A32S-MVUN R/L-16	40	32	30	250	22	50					
	EH-A40T-MVUN R/L-16	50	40	37	300	27	60					

MWLN^{R/L}

Multi Locking

+ WN □□

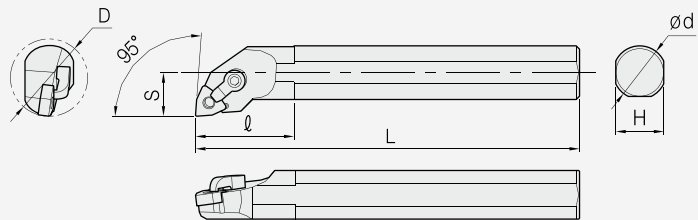

Insert	Item No.	Dimensions (mm)						Clamp	Clamp Screw	Shim	Shim Pin	Wrench
		ØD	Ød	H	L	S	l					
WN □□0604 □□	EH-S25R-MWLN R/L-06	32	25	23	200	17	36	MCL7N	MCSCR10/32-19	-	MSP3D3	W23.8L
	EH-S32S-MWLN R/L-06	40	32	30	250	22	50			MSW32	MSP3D	W19.8L
	EH-S40T-MWLN R/L-06	50	40	37	300	27	60			-	MSP4DS	W31.8L
WN □□0804 □□	EH-S25R-MWLN R/L-08	32	25	23	200	17	36	MCL6N	MCSCR1/4-21	-	MSP4D	W23.8L
	EH-S32S-MWLN R/L-08	40	32	30	250	22	50			MSW43	MSP4D	W23.8L
	EH-S40T-MWLN R/L-08	50	40	37	300	27	60			-	MSP4D	W23.8L

SCLC^{R/L}

Screw On

+ **CC** □ □

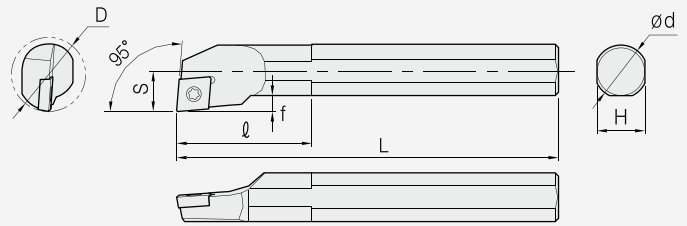

Insert	Item No.	Dimensions (mm)						Screw	Shim	Shim Screw	Wrench
		∅D	∅d	H	L	S	ℓ				
CC □ □ 0602 □ □	EH-S08K SCLC R/L 06	10	8	7	125	5	14	SCR02555			
	EH-S10K SCLC R/L 06	12	10	9	125	6	14	SCR02565	-	-	TW07P
	EH-S10M SCLC R/L 06	12	10	9	150	6	14				
	EH-S12M SCLC R/L 06	16	12	11	150	9	25				
	EH-S16R SCLC R/L 06	20	16	15	200	11	32				
CC □ □ 09T3 □ □	EH-S12M SCLC R/L 09	16	12	11	150	9	25	SCR03508	-	-	TW15P
	EH-S16R SCLC R/L 09	20	16	15	200	11	32.5				
	EH-S20S SCLC R/L 09	25	20	18	250	13	38	SCR03510	-	-	TW15P
	EH-S25R SCLC R/L 09	32	25	23	200	17	45				
CC □ □ 1204 □ □	EH-S25R SCLC R/L 12	32	25	23	200	17	45	SCR0411F	-	-	TW15P
	EH-S32S SCLC R/L 12	40	32	30	250	22	50		SSC42	SSCR0610	W40L
	EH-S40T SCLC R/L 12	50	40	37	300	27	60				TW15P
CC □ □ 0602 □ □	EH-A08F SCLC R/L 06	10	8	7.5	80	5	14	SCR02555			
	EH-A10H SCLC R/L 06	12	10	9.5	100	6	14	SCR02565	-	-	TW07P
	EH-A12K SCLC R/L 06	16	12	11	125	9	25				
CC □ □ 09T3 □ □	EH-A12K SCLC R/L 09	16	12	11	125	9	25	SCR03508	-	-	TW15P
	EH-A16M SCLC R/L 09	20	16	15	150	11	32.5				
	EH-A20Q SCLC R/L 09	25	20	19	180	13	-	SCR03510	-	-	TW15P
	EH-A25R SCLC R/L 09	32	25	24	200	17	45				
CC □ □ 1204 □ □	EH-A25R SCLC R/L 12	32	25	24	200	17	45	SCR0411F	-	-	TW15P
	EH-A32S SCLC R/L 12	40	32	31	250	32	50		SSC42	SSCR0610	W40L, TW15P

SCLP^{R/L}

Screw On

+ **CP** □ □

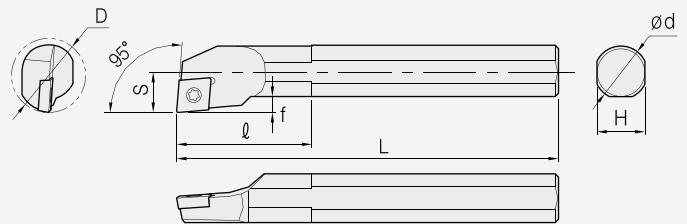

Insert	Item No.	Dimensions (mm)						Screw	Wrench
		∅D	∅d	H	L	S	ℓ		
CP □ □ 0802 □ □	EH-S10M SCLP R/L 08	12	10	9	150	6	-	SCR0305	TW09P
	EH-S12M SCLP R/L 08	16	12	11	150	8	15	SCR0307	
CP □ □ 0903 □ □	EH-S16N SCLP R/L 09	20	16	15	160	10	15	SCR0408	TW15P
	EH-S16R SCLP R/L 09	20	16	15	200	11	35		
	EH-S20N SCLP R/L 09	25	20	18	160	12.5	20		
CP □ □ 0802 □ □	EH-S20S SCLP R/L 09	25	20	15	250	12.5	20	SCR0305	TW09P
	EH-A10H SCLP R/L 08	12	10	9.5	100	9	-		
CP □ □ 0903 □ □	EH-A12K SCLP R/L 08	16	12	11	125	8	20	SCR0307	
	EH-A16M SCLP R/L 09	20	16	15	150	10	25	SCR0408	TW15P
EH-A20Q SCLP R/L 09	25	20	19	180	12.5	28			

SDQC^{R/L}

Screw On

+ DC □□

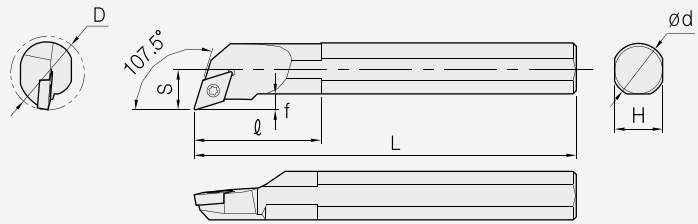

Insert	Item No.	Dimensions (mm)							Screw	Wrench
		ØD	Ød	H	L	S	l	f		
DC □□ 0702 □□	EH-S10M-SDQCR R/L-07	13	10	9	150	7	20	2.5	SCR02555	TW07P
	EH-S12M-SDQCR R/L-07	16	12	11	150	9	22	3.5	SCR02565	
	EH-S16R-SDQCR R/L-07	20	16	15	200	11	27	4	SCR03508	
DC □□ 11T3 □□	EH-S16R-SDQCR R/L-11	20	16	15	200	11	32	4	SCR03508	TW15P
	EH-S20S-SDQCR R/L-11	25	20	18	250	13	32	4.5	SCR03510	
	EH-S25R-SDQCR R/L-11	32	25	23	200	17	32	7	SCR03510	
DC □□ 0702 □□	EH-A10H-SDQCR R/L-07	13	10	9.5	100	7	20	2	SCR02555	TW07P
	EH-A12K-SDQCR R/L-07	16	12	11	125	9	22	3	SCR02565	
DC □□ 11T3 □□	EH-A16M-SDQCR R/L-11	20	16	15	150	11	27	3	SCR03508	TW15P
	EH-A20Q-SDQCR R/L-11	25	20	19	180	13	32	3	SCR03510	
	EH-A25R-SDQCR R/L-11	32	25	24	200	17	32	4	SCR03510	

SDUC^{R/L}

Screw On

+ DC □□

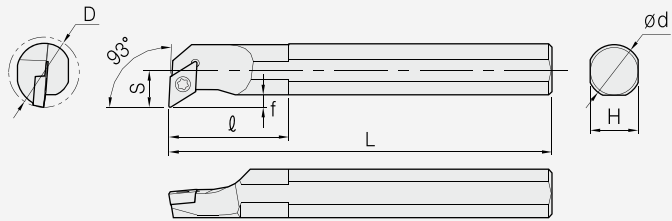

Insert	Item No.	Dimensions (mm)							Screw	Wrench
		ØD	Ød	H	L	S	l	f		
DC □□ 0702 □□	EH-S10M-SDUCR R/L-07	13	10	9	150	7	0	2.5	SCR02555	TW07P
	EH-S12M-SDUCR R/L-07	16	12	11	150	9	22	3.5	SCR02565	
	EH-S16R-SDUCR R/L-07	20	16	15	200	11	27	4	SCR03508	
DC □□ 11T3 □□	EH-S16R-SDUCR R/L-11	20	16	15	200	11	27	4	SCR03508	TW15P
	EH-S20S-SDUCR R/L-11	25	20	18	250	13	35	4.3	SCR03510	
	EH-S25R-SDUCR R/L-11	32	25	23	200	17	46	6.8	SCR03510	
DC □□ 0702 □□	EH-S32S-SDUCR R/L-11	40	32	30	250	22	50	8.4	SCR03510	TW15P
	EH-A10H-SDUCR R/L-07	13	10	9.5	100	7	0	2	SCR02555	
	EH-A12K-SDUCR R/L-07	16	12	11	125	9	22	3	SCR02565	
DC □□ 11T3 □□	EH-A16M-SDUCR R/L-07	20	16	15	150	11	27	3	SCR03508	TW07P
	EH-A20Q-SDUCR R/L-11	25	20	19	180	13	35	3	SCR03510	
	EH-A25R-SDUCR R/L-11	32	25	24	200	17	46	4.5	SCR03510	

SDZC^{R/L} Screw On

+ DC □□

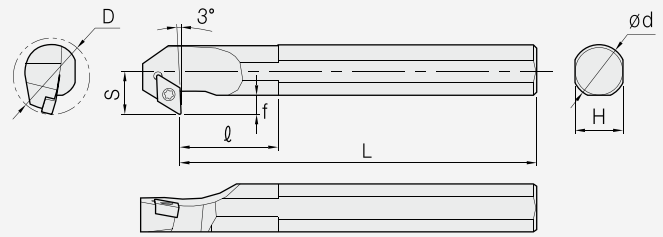

Insert	Item No.	Dimensions (mm)							Screw	Shim	Shim Screw	Wrench
		øD	ød	H	L	S	l	f				
DC□□0702□□	EH-S16R SDZC R/L 07	20	16	15	200	11	29	4	SCR02565	-	-	TW07P
	EH-S20S SDZC R/L 07	25	20	18	250	13	36.5	4.5	SCR03510	-	-	TW15P
DC□□11T3□□	EH-S25R SDZC R/L 11	32	25	23	200	17	30	6.9	SCR03512	SSD32	SSCR0509	TW15P,W35L
	EH-S32S SDZC R/L 11	40	32	30	250	22	39	8.4	SCR03510	-	-	TW15P
	EH-S40T SDZC R/L 11	50	40	37	300	27	47	9.4	SCR03512	SSD32	SSCR0509	TW15P,W35L
	EH-A25R SDZC R/L 11	32	25	24	200	17	30	4.5	SCR03512	SSD32	SSCR0509	TW15P,W35L

SSKC^{R/L} Screw On

+ SC □□

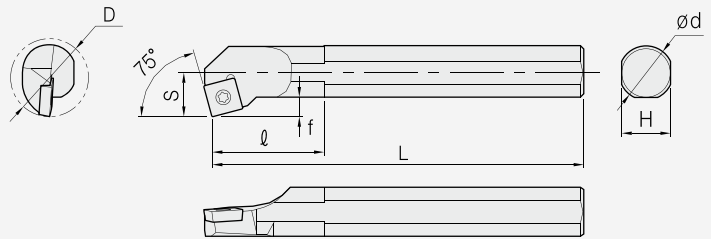

Insert	Item No.	Dimensions (mm)							Screw	Shim	Shim Screw	Wrench
		øD	ød	H	L	S	l	f				
SC□□09T3□□	EH-S12M SSKC R/L 09	16	20	11	150	9	26	SCR03507	-	-	-	
	EH-S16R SSKC R/L 09	20	16	15	200	11	40	SCR03508	-	-	TW15P	
	EH-S20S SSKC R/L 09	25	20	18	250	13	46	SCR03508	-	-	TW15P	
SC□□1204□□	EH-S25R SSKC R/L 12	32	25	23	200	17	36	SCR0411F	SSC42	SSCR0610	TW15P,W40L	
	EH-S32S SSKC R/L 12	40	32	30	250	22	43	SCR0411F	SSC42	SSCR0610	TW15P,W40L	
SC□□09T3□□	EH-A12K SSKC R/L 09	16	12	11	125	9	26	SCR03507	-	-	-	
	EH-A16M SSKC R/L 09	20	16	15	150	11	32	SCR03508	-	-	TW15P	
	EH-A20Q SSKC R/L 09	25	20	19	180	13	34	SCR03508	-	-	TW15P	
SC□□1204□□	EH-A25R SSKC R/L 12	32	25	24	200	17	36	SCR0411F	SSC42	SSCR0610	TW15P	
	EH-A32S SSKC R/L 12	40	32	31	250	22	43	SCR0411F	SSC42	SSCR0610	TW15P,W40L	

SSKP^{R/L}

Screw On

+ SP □□

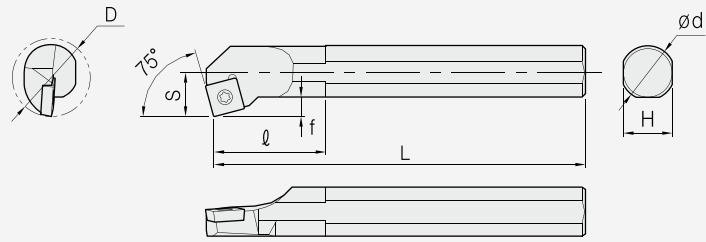

Insert	Item No.	Dimensions (mm)						Screw	Wrench
		∅D	∅d	H	L	S	l		
SP□□0903□□	EH-S12M SSKP R/L 09	16	12	11	150	8	18	SCR0307	TW09P
	EH-S16N SSKP R/L 09	20	16	15	160	10	30		
	EH-S16R SSKP R/L 09	20	16	15	200	10	32		
	EH-S20N SSKP R/L 09	25	20	18	160	12.5	32		
	EH-S20S SSKP R/L 09	25	20	18	250	12.5	35		
SP□□0903□□	EH-A12K SSKP R/L 09	16	12	11	125	8	21	SCR03508	TW09P
	EH-A16M SSKP R/L 09	20	16	15	150	10	30	SCR0307	
	EH-A20Q SSKP R/L 09	25	20	19	180	12.5	32	SCR0307	

STFC^{R/L}

Screw On

+ TC □□

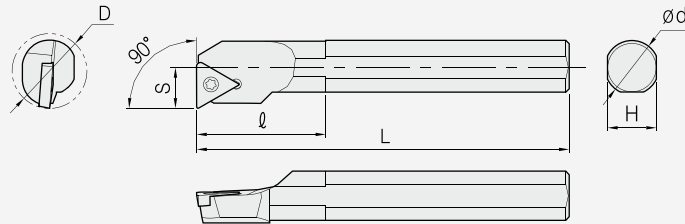

Insert	Item No.	Dimensions (mm)						Screw	Shim	Shim Screw	Wrench
		∅D	∅d	H	L	S	l				
TC□□0902□□	EH-S10M STFC R/L 09	13	10	9	150	7	23	SCR02206	-	-	TW06P
	EH-S12M STFC R/L 09	16	12	11	150	9	28				
TC□□1102□□	EH-S12M STFC R/L 11	16	12	11	150	9	30	SCR02565	-	-	TW07P
	EH-S16R STFC R/L 11	20	16	15	200	11	35				
	EH-S20S STFC R/L 11	25	20	18	250	13	36				
TC□□16T3□□	EH-S20S STFC R/L 16	25	20	18	250	13	36	SCR03510	-	-	TW15P
	EH-S25R STFC R/L 16	32	25	23	200	17	49				
TC□□16T3□□	EH-S32S STFC R/L 16	40	32	30	250	22	50	SCR03512	SST32	SSCR0509	TW15P,W35L
	EH-S40T STFC R/L 16	50	40	37	300	27	60				
	EH-A10M STFC R/L 09	13	10	9.5	100	7	23				
TC□□0902□□	EH-A12K STFC R/L 09	16	12	11	125	9	23	SCR02206	-	-	TW06P
	EH-A12K STFC R/L 11	16	12	11	125	9	30				
	EH-A16M STFC R/L 11	20	16	15	150	11	30				
TC□□1102□□	EH-A20Q STFC R/L 11	25	20	19	180	13	36	SCR02565	-	-	TW07P
	EH-A25R STFC R/L 16	32	25	24	200	17	49				
TC□□16T3□□	EH-A25R STFC R/L 16	32	25	24	200	17	49	SCR03510	-	-	TW15P
	EH-A32S STFC R/L 16	40	32	31	250	22	50				

STFP^{R/L}

Screw On

+ **TP** □ □

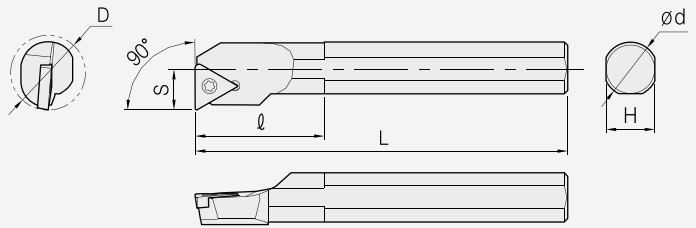

Insert	Item No.	Dimensions (mm)						Screw	Wrench
		ØD	ød	H	L	S	ℓ		
TP□□1103□□	EH-S10M STFP R/L 11	12	10	9	150	6	-	SCR030508	TW09P
	EH-S12M STFP R/L 11	16	12	11	150	8	10	SCR0307	TW09P
	EH-S16N STFP R/L 11	20	16	15	160	10	12		
	EH-S16R STFP R/L 11	20	16	15	200	10	12		
TP□□1604□□	EH-S20N STFP R/L 16	25	20	18	160	12.5	32	SCR0408	TW15P
	EH-S20S STFP R/L 16	25	20	18	250	12.5	14		
TP□□1103□□	EH-A10H STFP R/L 11	12	10	9.5	100	6	-	SCR030508	TW09P
	EH-A12K STFP R/L 11	16	12	11	125	8	10	SCR0307	TW09P
	EH-A16M STFP R/L 11	20	16	15	150	10	23		
TP□□1604□□	EH-A20Q STFP R/L 16	25	20	19	180	12.5	41	SCR0408	TW15P

STWP^{R/L}

Screw On

+ **TP** □ □

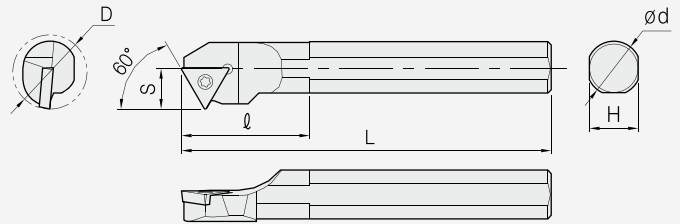

Insert	Item No.	Dimensions (mm)						Screw	Wrench
		ØD	ød	H	L	S	ℓ		
TPGH1102□□	EH-S10M STWP R/L 11	12	10	9	150	6	23	SCR030508	TW09P
TPGH1103□□	EH-S12M STWP R/L 11	16	12	11	150	8	30	SCR0306	TW09P
	EH-S16R STWP R/L 11	20	16	15	180	10	35		
	EH-S20R STWP R/L 11	25	20	19	200	12.5	40		

SVJC^{R/L}

Screw On

+ **VC** □ □

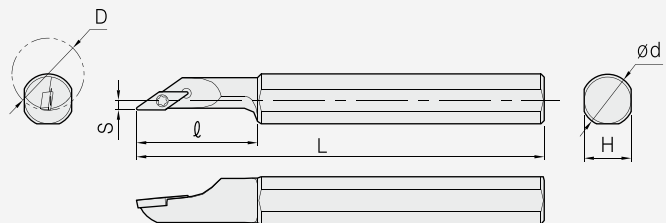

Insert	Item No.	Dimensions (mm)						Screw	Wrench
		ØD	ød	H	L	S	ℓ		
VCMT0802□□	EH-S12M SVJC R/L 08	16	12	11	150	2	26	SCR0204	TW06P
	EH-S16Q SVJC R/L 08	20	16	15	180	2	36		

SVQB^{R/L}

Screw On

+ VB □ □

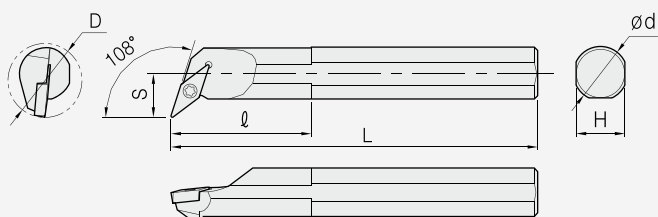

Insert	Item No.	Dimensions (mm)						Screw	Shim	Shim Screw	Wrench
		ØD	Ød	H	L	S	l				
VB □ □ 1604 □ □	EH-S32S SVQB R/L 16	40	32	30	250	22	56	SCR03512	SSV32	SSCR0509	TW15P,W35L
	EH-S40T SVQB R/L 16	50	40	37	300	27	64				
	EH-A32S SVQB R/L 16	40	32	31	250	22	56				

SVQC^{R/L}

Screw On

+ VC □ □

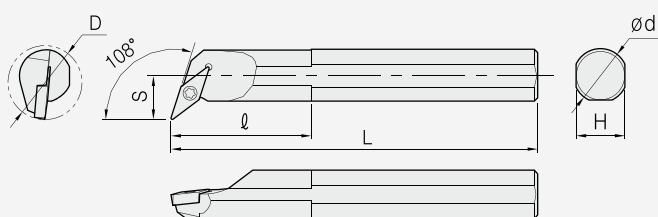

Insert	Item No.	Dimensions (mm)						Screw	Shim	Shim Screw	Wrench
		ØD	Ød	H	L	S	l				
VC □ □ 1103 □ □	EH-S16R SVQC R/L 11	20	16	15	200	11	35	SCR02565	-	-	TW07P
	EH-S20S SVQC R/L 11	25	20	18	250	13	38				
	EH-S25R SVQC R/L 11	32	25	23	200	17	42				
VC □ □ 1303 □ □	EH-S20S SVQC R/L 13	25	20	18	250	13	42	SCR0307	-	-	TW07P
	EH-S25R SVQC R/L 13	32	25	23	200	17	45				
VC □ □ 1604 □ □	EH-S25R SVQC R/L 16	32	25	23	200	17	50	SCR03510	-	-	TW15P
	EH-S32S SVQC R/L 16	40	32	30	250	22	56				
	EH-S40T SVQC R/L 16	50	40	37	300	27	64				

SVUB^{R/L}

Screw On

+ VB □ □

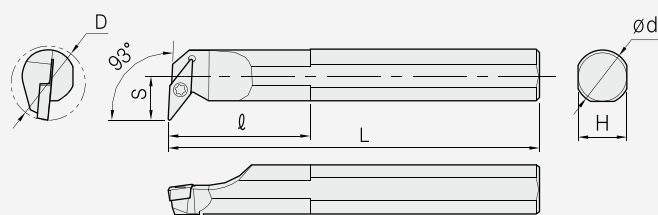

Insert	Item No.	Dimensions (mm)						Screw	Shim	Shim Screw	Wrench
		ØD	Ød	H	L	S	l				
VB □ □ 1604 □ □	EH-S32S SVUB R/L 16	40	32	30	250	22	56	SCR03510	SSV32	SSCR0509	TW15P,W35L
	EH-S40T SVUB R/L 16	50	40	37	300	27	64				
	EH-A32S SVUB R/L 16	40	32	31	250	22	56				

SVUC^{R/L} Screw On

+ VC □ □

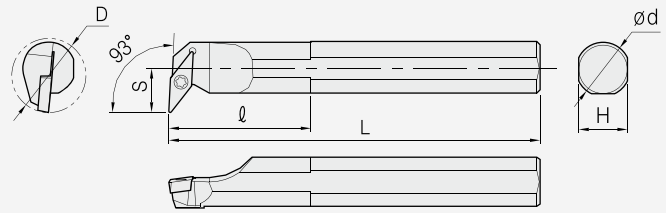

Insert	Item No.	Dimensions (mm)						Screw	Shim	Shim Screw	Wrench
		ØD	ød	H	L	S	l				
VC □ □ 1103 □ □	EH-S16R SVUC R/L 11	22	16	15	200	13	30	SCR02565	-	-	TW07P
	EH-S20S SVUC R/L 11	25	20	18	250	14	33				
	EH-S25T SVUC R/L 11	32	25	23	300	17	38				
VC □ □ 1303 □ □	EH-S20S SVUC R/L 13	28	20	18	250	16	35	SCR0307	-	-	TW09P
	EH-S25R SVUC R/L 13	32	25	23	200	17	40				
VC □ □ 1604 □ □	EH-S25R SVUC R/L 16	32	25	23	200	19	50	SCR03510	-	-	TW15P
	EH-S32S SVUC R/L 16	40	32	30	250	22	56	SCR03512	SSV32	SSCR0509	TW15P W35L
	EH-S40T SVUC R/L 16	50	40	37	300	27	64				

MCLN^{R/L}

Multi Locking

+ **CN**□□

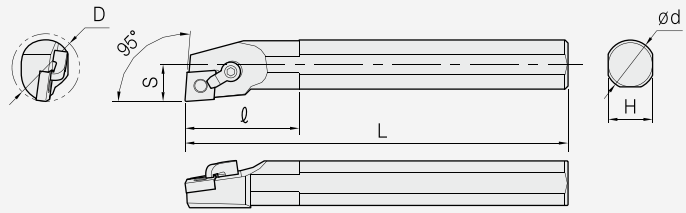

Insert	Item No.	Dimensions (mm)						Clamp	Clamp Screw	Shim	Shim Pin	Wrench
		$\varnothing D$	$\varnothing d$	H	L	S	l					
CN□□0903□□	EH-S20S-MCLN R/L-09	25	20	18	250	13	30	MCL7N	MCSCR10-32-19	-	MSP3D3	W19.8L
	EH-S25R-MCLN R/L-09	32	25	23	200	17	36					W23.8L
CN□□1204□□	EH-S25R-MCLN R/L-12	32	25	23	200	17	36	MCL6N	MCSCR1/4-21	MSC43	MSP4D	W31.8L
	EH-S32S-MCLN R/L-12	40	32	30	250	22	50					W23.8L
CN□□1204□□	EH-S40T-MCLN R/L-12	50	40	37	300	27	60	MCL6N	MCSCR1/4-21	-	MSP4DS	W31.8L
	EH-A25R-MCLN R/L-12	32	25	23	200	17	40					W23.8L
CN□□1204□□	EH-A32S-MCLN R/L-12	40	32	30	250	22	50	MCL6N	MCSCR1/4-21	MSC43	MSP4D	W31.8L
	EH-A40T-MCLN R/L-12	50	40	37	300	27	60					W23.8L

MDUN^{R/L}

Multi Locking

+ **DN**□□

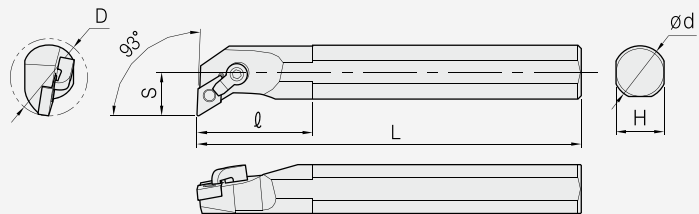

Insert	Item No.	Dimensions (mm)						Clamp	Clamp Screw	Shim	Shim Pin	Wrench
		$\varnothing D$	$\varnothing d$	H	L	S	l					
DN□□1504□□	EH-S32S-MDUN R/L-15-3	40	32	30	250	22	50	MCL6N	MCSCR1/4-21	MSD43	MSP4D	W31.8L
	EH-S40T-MDUN R/L-15-3	50	40	37	300	27	60					W23.8L
	EH-A32S-MDUN R/L-15-3	40	32	30	250	22	50					

MSKN^{R/L}

Multi Locking

+ **SN**□□

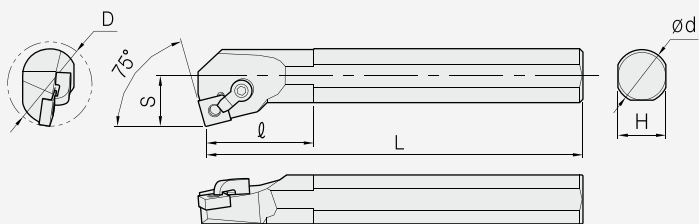

Insert	Item No.	Dimensions (mm)						Clamp	Clamp Screw	Shim	Shim Pin	Wrench
		$\varnothing D$	$\varnothing d$	H	L	S	l					
SN□□1204□□	EH-S25R-MSKN R/L-12	32	25	23	200	17	36	MCL8N1	MCSCR5/16-28	MSS43	MSP4D	W39.7L
	EH-S32S-MSKN R/L-12	40	32	30	250	22	50					W23.8L
	EH-S40T-MSKN R/L-12	50	40	37	300	27	60					
SN□□1204□□	EH-A25R-MSKN R/L-12	32	25	23	200	17	40	MCL8N1	MCSCR5/16-28	-	MSP4DS	W39.7L
	EH-A32S-MSKN R/L-12	40	32	30	250	22	50					W23.8L
	EH-A40T-MSKN R/L-12	50	40	37	300	27	60					